

## HP480 - PROBE FOR THE MEASUREMENT OF THE DEW POINT IN COMPRESSED AIR SYSTEMS

Compressed air is used for several purposes, many of which require compressed air with low a humidity level, and so comes the need to know the dew point (Dew Point - DP) of water vapour in the compressed air that circulates in the system. The HP480 probe is designed specifically for this purpose.

The use of dew point measurement in order to limit moisture in compressed air distribution systems has many advantages:

- prevents corrosion of metal pipes;
- in cold areas, prevents the formation of ice inside the pipes leading to obstruction of the pipes themselves;
- prevents bacterial growth in plants for medical use
- reduces maintenance costs of pneumatic drives, maintaining the proper lubrication of moving parts;
- improves the quality of products coming into contact with air, for example in the drying process of granulates.

The probe can be installed in any position. The connection to the compressed air can be achieved with a threaded connection or with a quick connection.

The connection allows for quick installation and removal of the probe without stopping the system. There are 3 different couplings supplied: 1/4" Italian, German, and American standard.

The probe is equipped with a filter made of sintered steel, stainless steel measuring chamber and control valve of the air flow. Suitable for measurement of compressed air with dew point up to class 3 according to standard ISO8573-1.

### TECHNICAL SPECIFICATIONS

Relative humidity	HP480	HP481
Sensor	capacitive	capacitive
Measuring range	0...100%RH	0...100%RH
Accuracy (@ T = 15...35 °C)	± 1,5%RH (0.90%RH), ± 2%RH (remaining field)	± 1,5%RH (0.90%RH), ± 2%RH (remaining field)
Accuracy (@ T = -40...+60 °C)	± (1,5 + 1,5% of the measured value)%RH	± (1,5 + 1,5% of the measured value)%RH
Long term stability	< 1%RH/year	< 1%RH/year
Temperature		
Sensor	Pt100	Pt100
Measuring range	-40...+60 °C	-40...+60 °C
Accuracy	± 0,25 °C	± 0,25 °C
Dew point		
Sensor	Parameter calculated from the measurement of temperature and relative humidity	Parameter calculated from the measurement of temperature and relative humidity
Measuring range	-40...+60 °C DP	-40...+60 °C DP
Accuracy (@ T = 20 °C)	± 2 °C DP (-40...-20 °C DP) ± 1,5 °C DP (-20...0 °C DP) ± 1 °C DP (0...+20 °C DP) ± 0,5 °C DP (+20...+60 °C DP)	± 3 °C DP (-40...0 °C DP) ± 2 °C DP (0...+20 °C DP)
Accuracy (@ T = -40...+60 °C)	See graph 1	See graph 2
General features		
Connection	G 1/2" or G 1/4" or quick coupling	G 1/2"
Regulation of the air flow	From 0,2 to 3 l/min	
Cable length	2m	2m (other lenghts on request)
Filter	Sintered 15µ AISI 316 steel	Sintered 15µ AISI 316 steel
Material of the measuring chamber	AISI 304 stainless steel	AISI 304 stainless steel
Operating temperature of the probe	-40...+80 °C	-40...+80 °C
Operating pressure of the probe	Up to 16 bar	From -1 to 8 bar
Protection degree	IP65	IP65
Compatibility with ethylene oxide (C2H4O)		The maximum allowed concentration in continuous operation which causes a deviation within 2% is 3 ppm

Graph 1: accuracy of the dew point measurement (DP) - HP480 Probe

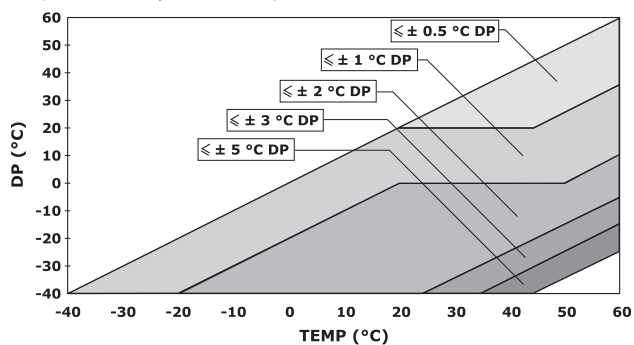

Graph 2: accuracy of the dew point measurement (DP) - HP481 probe

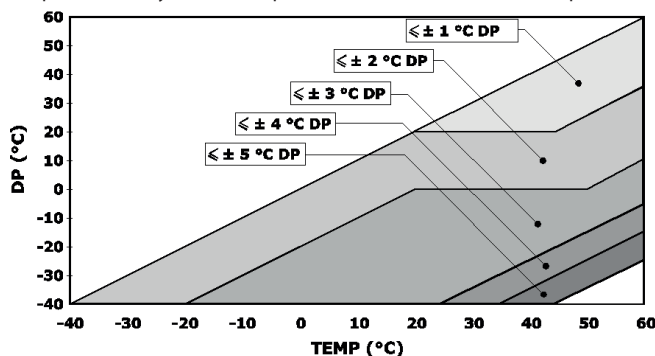

## HP481 - COMBINED RELATIVE HUMIDITY AND TEMPERATURE PROBES FOR PIPES

HP481 is a combined relative humidity and temperature probe suitable for in-line installation. The probe can be used in pressurized pipes, or in which vacuum is required. It is equipped with a G 1/2" threading for the connection to the system and can be installed in any position. The probe is equipped with a sintered steel filter.

## INSTALLATION

The probes can be connected to the pipe in three ways:

- A. by using the measuring chamber with a quick coupling (only HP480);
- B. by using the measuring chamber with a threaded G 1/4" connection (only HP480);
- C. directly (without measuring chamber) with a threaded G 1/2" connection.

Connection with measuring chamber and quick coupling:

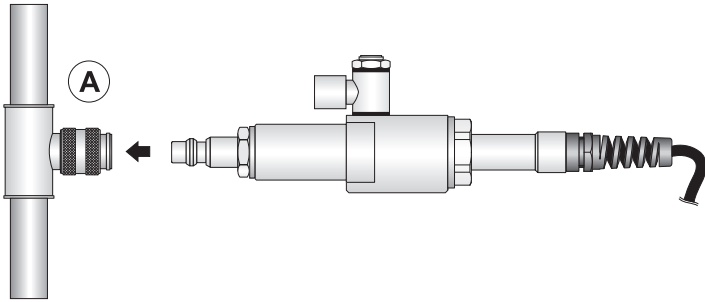

To connect with quick coupling, you can use one of the standard 1/4" couplings provided. Other couplings than those supplied can be used, provided that they have a G 1/4" thread on the side that fits into the probe.

Connection with measuring chamber and threaded connection:

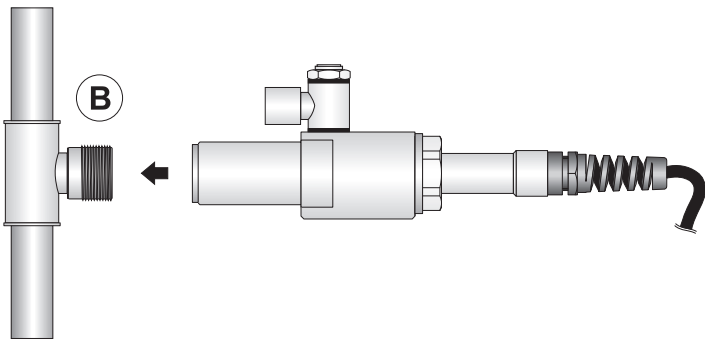

For the connection by threaded coupling, the connection must have an external G 1/4" thread on the side which will be placed in the probe. The connection must be airtight. When installing or removing the probe, it is necessary to depressurize the system.

Direct connection (without measuring chamber) and threaded connection:

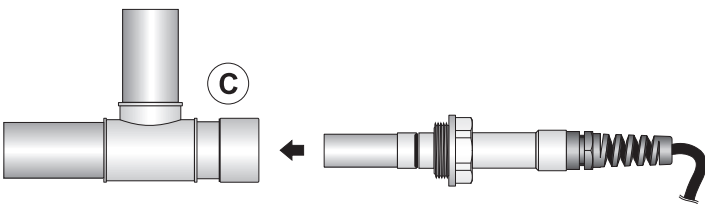

For direct connection of the probe, use a fitting with internal G 1/2" thread on the side which will be placed in the probe. The connection must be airtight. When installing or removing the model HP480, it is necessary to depressurize the system. Ensure that the probe does not obstruct the normal flow of air through the distribution line.

In all modes of installation, it is recommended that you place in the plant, upstream of the sensor, a safety valve to be closed manually in case of maintenance of the probe.

Periodically check the cleanliness of the sintered filter of the probe, in order to maintain optimum response characteristics of the probe. The filter can be washed with a detergent that leaves no traces.

## DIMENSIONS

Dimensions (mm) of the probe without measuring chamber:

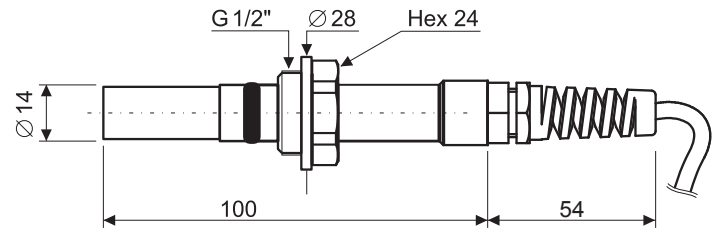

Dimensions (mm) of the probe with measuring chamber, without quick coupling (only HP480):

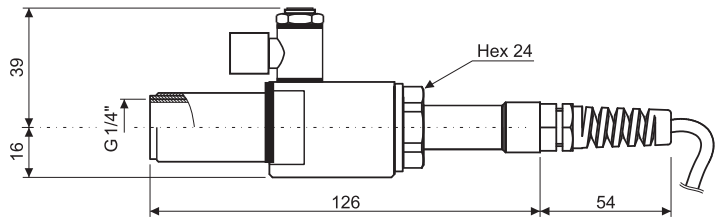

Dimensions (mm) of the probe with measuring chamber and quick coupling (only HP480):

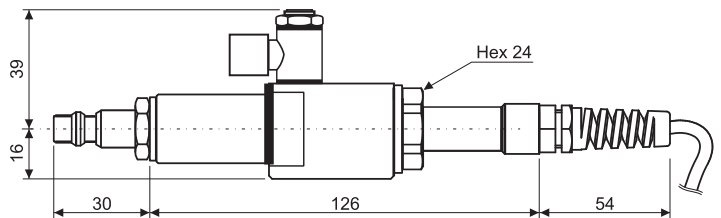

## ORDERING CODES

**HP480:** Interchangeable temperature and humidity probe, complete with SICRAM module. Connection cable 2m. Equipped with 15µ sintered AISI 316 stainless steel filter, measuring chamber, air flow regulation valve, and three 1/4" quick couplings (standard Italian, German, and American).

**HP481:** Interchangeable temperature and humidity combined probe, complete with SICRAM module. Connection cable 2 m. Equipped with 15µ sintered AISI 316 stainless steel filter, G 1/2" threading.