

Operating manual

Ultrasonic anemometers

HD51.3D4R

HD51.3D4R-AL



Companies / Brands of GHM

Members of GHM GROUP:

GREISINGER

HONSBURG

Martens

IMTRON

Delta OHM

VAL.CO

www.deltaohm.com

Keep for future reference.

TABLE OF CONTENTS

1	INTRODUCTION	3
2	TECHNICAL SPECIFICATIONS	4
3	DESCRIPTION	5
4	MEASURING PRINCIPLE OF WIND SPEED AND DIRECTION	6
5	INSTALLATION	7
5.1	ALIGNMENT OF THE INSTRUMENT	8
5.2	ELECTRICAL CONNECTIONS	9
5.2.1	RS232 SERIAL CONNECTION	10
5.2.2	RS485 SERIAL CONNECTION	10
5.2.3	RS422 SERIAL CONNECTION	11
5.2.4	ANALOG OUTPUTS CONNECTION	12
5.2.5	CONNECTION OF HEATING SYSTEM	12
5.2.6	AUXILIARY RS485 SERIAL OUTPUT CONNECTION	13
5.3	SERIAL OUTPUT PROTOCOL	13
6	CONFIGURATION	14
6.1	SERIAL COMMANDS	14
7	ASCII PROPRIETARY MODE	25
8	NMEA MODE	26
9	MODBUS-RTU MODE	28
10	INSTRUMENT STORAGE	30
11	SAFETY INSTRUCTIONS	30
12	ORDERING CODES	31

1 INTRODUCTION

HD51.3D4R e **HD51.3D4R-AL** are 2-axes ultrasonic static anemometers with integrated **heater**. The heater prevents the accumulation of snow and ice formation, allowing accurate measurements in all environmental conditions.

HD51.3D4R-AL is equipped with an **enhanced heater**, for rapid defrosting, and an **anodized aluminum alloy housing** with anti-corrosion coating that makes it possible to use the instrument even in a particularly aggressive atmosphere (e.g., marine environment). The anemometer satisfies the requirements of the **MIL-STD-810G Method 509.6** standard (salt fog anti-corrosion test). The high immunity to electromagnetic disturbances makes the anemometer suitable for measurements in electrically noisy environments (e.g., industrial environments, wind farms, etc.).

The anemometers measure:

- Wind speed up to 80 m/s (HD51.3D4R-AL) or 85 m/s (HD51.3D4R).
- Wind direction.
- Wind Gust.
- Atmospheric pressure (with internal sensor).

The average of wind speed and direction over a period configurable up to 10 minutes is calculated.

Available outputs:

- **RS232, RS485** and **RS422** isolated serial outputs with **NMEA** and **MODBUS-RTU** standard protocols and ASCII proprietary protocol.
- Two analog outputs, for wind speed and direction or for velocity U-V cartesian components, which are factory-configurable within 4÷20 mA (standard), 0÷1 V, 0÷5 V or 0÷10 V (**to be specified when ordering**).

Mounting on \varnothing 40 mm mast. The electric connection is performed through the M23 connector situated at the bottom of the instrument.

Power supply of the instrument (excluding heater) 12...30 Vdc. Power supply of the heater 24 Vdc.

All instrument sensors are factory-calibrated and do not require additional interventions of the user (field calibration is not required).

The absence of moving parts minimizes the instrument maintenance.

2 TECHNICAL SPECIFICATIONS

	HD51.3D4R	HD51.3D4R-AL
Wind speed		
Used sensor	Ultrasounds	
Measuring range	0...85 m/s	0...80 m/s
Resolution	0.01 m/s	
Accuracy	± 0.2 m/s or $\pm 2\%$, the greatest (0...60 m/s), $\pm 3\%$ (> 60 m/s)	
Wind direction		
Used sensor	Ultrasounds	
Measuring range	0...359.9°. In order to avoid oscillations of the analog output around 0°, the extended range 0...539.9° can be set.	
Resolution	0.1°	
Accuracy	$\pm 2^\circ$ RMSE (wind speed > 2 m/s)	
Atmospheric Pressure		
Used sensor	Piezoresistive	
Measuring range	300...1100 hPa	
Resolution	0.1 hPa	
Accuracy	± 0.5 hPa @ 20 °C	
General features		
Instrument power supply (excluding heater)	12...30 Vdc	
Heater power supply	24 Vdc $\pm 10\%$	
Instrument power consumption (excluding heater)	60 mA @ 24 Vdc	
Heater power consumption	15 W @ 24 Vdc	80 W @ 24 Vdc
Serial outputs	Isolated RS232, RS485 and RS422	
Communication protocols	NMEA, MODBUS-RTU, ASCII proprietary	
Analog outputs	2 analog outputs, for wind speed and direction or for velocity U-V cartesian components. Output at choice among 4...20 mA (standard, max. load 500 Ω), 0...1 V, 0...5 V and 0...10 V The outputs are isolated from the power supply	
Measurement interval	From 250 ms to 1 s	
Wind speed averaging interval	Configurable from 1 s to 10 min	
Wind Gust calculation interval	Configurable from 1 s to 10 min	
Electrical connection	19-pole M23 male connector	
Operating temperature	-40...+60 °C	
Protection degree	IP 66	
Anti-corrosion test	According to MIL-STD-810G Method 509.6 (48 hours of exposure + 48 hours of drying)	
Survival speed	90 m/s	100 m/s
Weight	640 g approx.	1.4 kg approx.
Housing	ASA with aluminum and AISI 316 metal parts	Anodized aluminum alloy and AISI 316
Installation	on mast \varnothing 40 mm external and \varnothing 36 mm internal	

Dimensions:

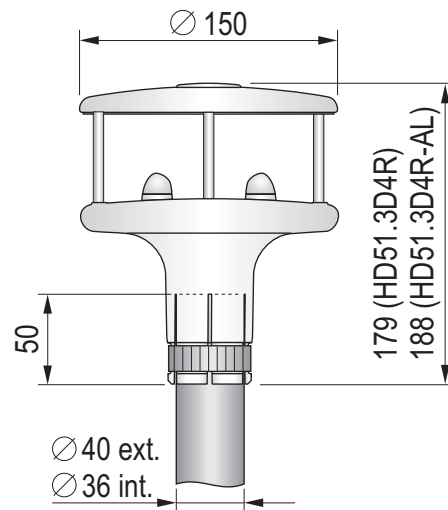

3 DESCRIPTION

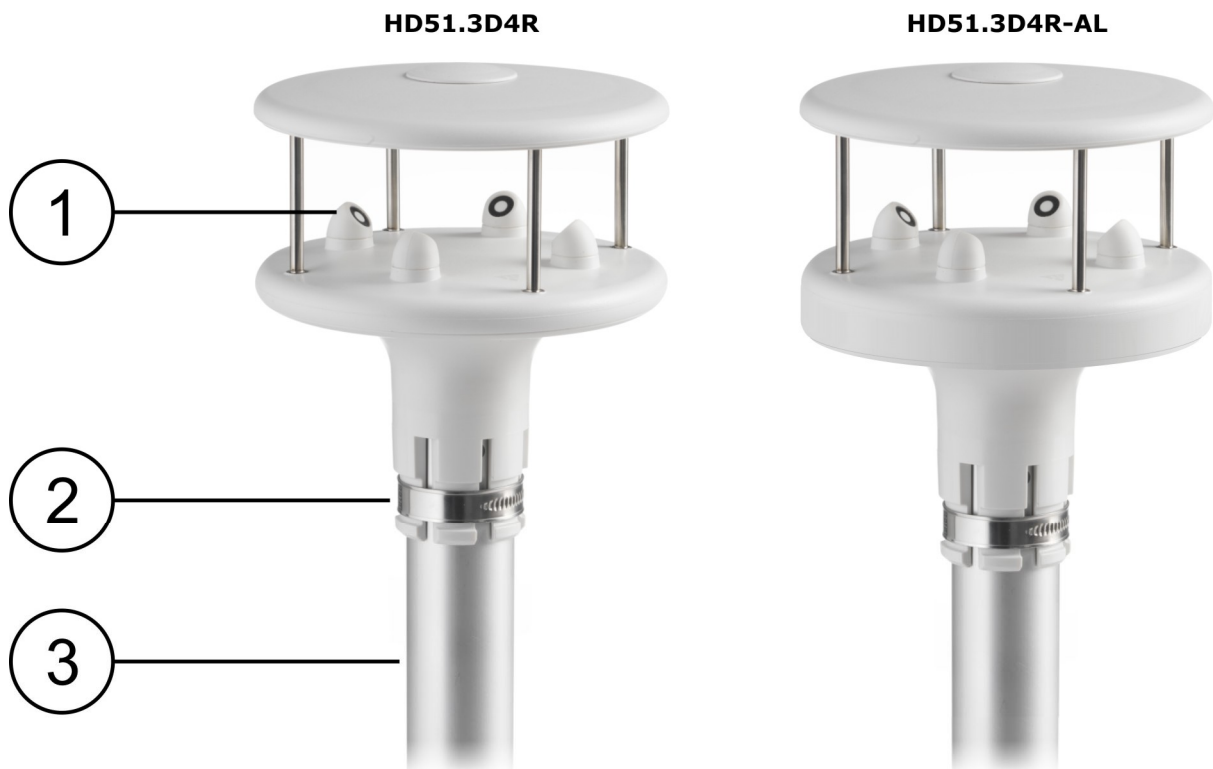

1. Ultrasonic sensors for the measurement of wind speed and direction.
2. Fixing clamp to $\varnothing 40$ mm mast.
3. $\varnothing 40$ mm mast.

4 MEASURING PRINCIPLE OF WIND SPEED AND DIRECTION

Wind speed and direction are determined by measuring the time taken by ultrasonic pulses to cover the distance from the transducer that generates the pulse to the receiving transducer.

The instrument uses 2 pairs of transducers oriented along two orthogonal axes. Detecting the wind speed along two axes allows determining not only the intensity but also the wind direction.

The instrument measures the travel time of the ultrasonic pulse between the two transducers of the same pair in both directions. The travel times in the two opposed directions are defined as t_A (forward direction time) and t_R (reverse direction time).

If wind speed is zero, t_A and t_R values are the same. In the presence of wind, one of the two time values is greater than the other and the comparison between the two time values allows determining the direction and the intensity of the wind.

Measuring the travel time in both directions allows cancelling the dependence of the transmission speed of ultrasounds in the air from the environmental conditions of temperature, humidity and barometric pressure.

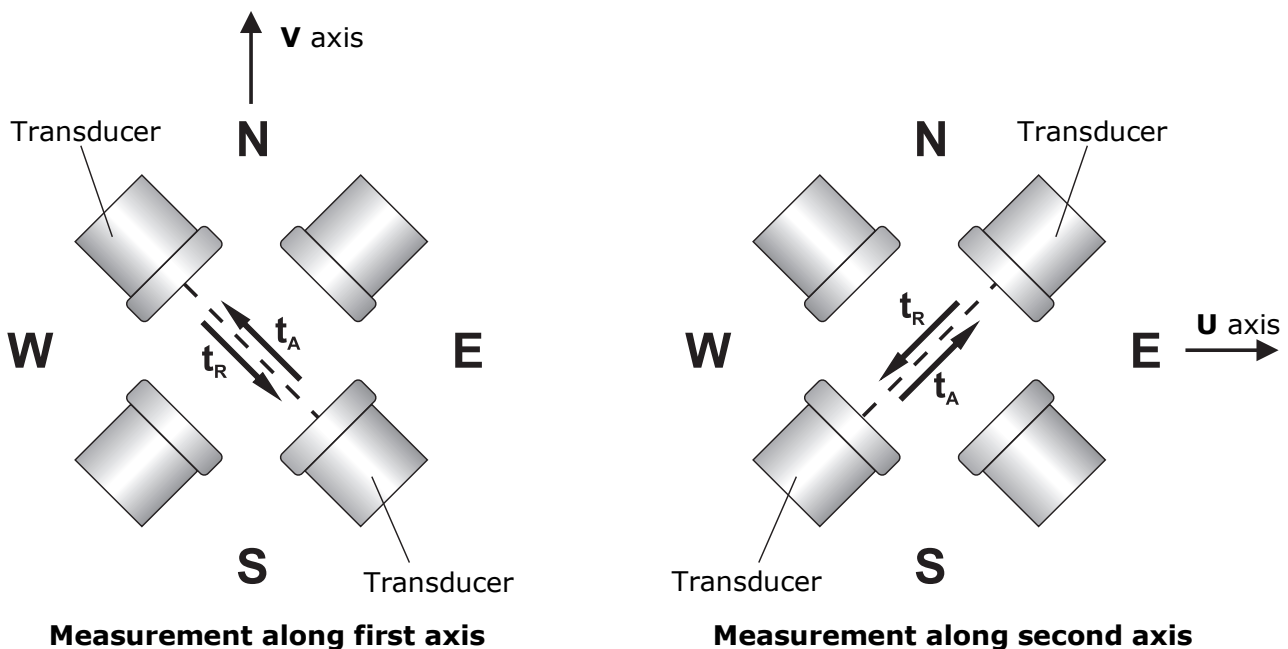

The travel times of the ultrasonic pulses are given by:

$$t_A = \frac{D}{C + V_w} \quad t_R = \frac{D}{C - V_w}$$

Where:

D = Distance between the two transducers of the same pair

C = Sound speed

V_w = Component of wind speed along the measurement axis

Measuring the two travel times allows determining the wind speed component:

$$V_w = \frac{D}{2} \cdot \left(\frac{1}{t_A} - \frac{1}{t_R} \right)$$

5 INSTALLATION

To install the instrument, pass the connection cable inside the support mast and connect the 19-pole M23 female connector of the cable to the 19-pole M23 male connector situated at the bottom of the instrument. Ensure connection stability by tightening the connector external nut.

Align the instrument (see par. 5.1), then fix it on the support mast by tightening the cable tie at the bottom of the instrument.

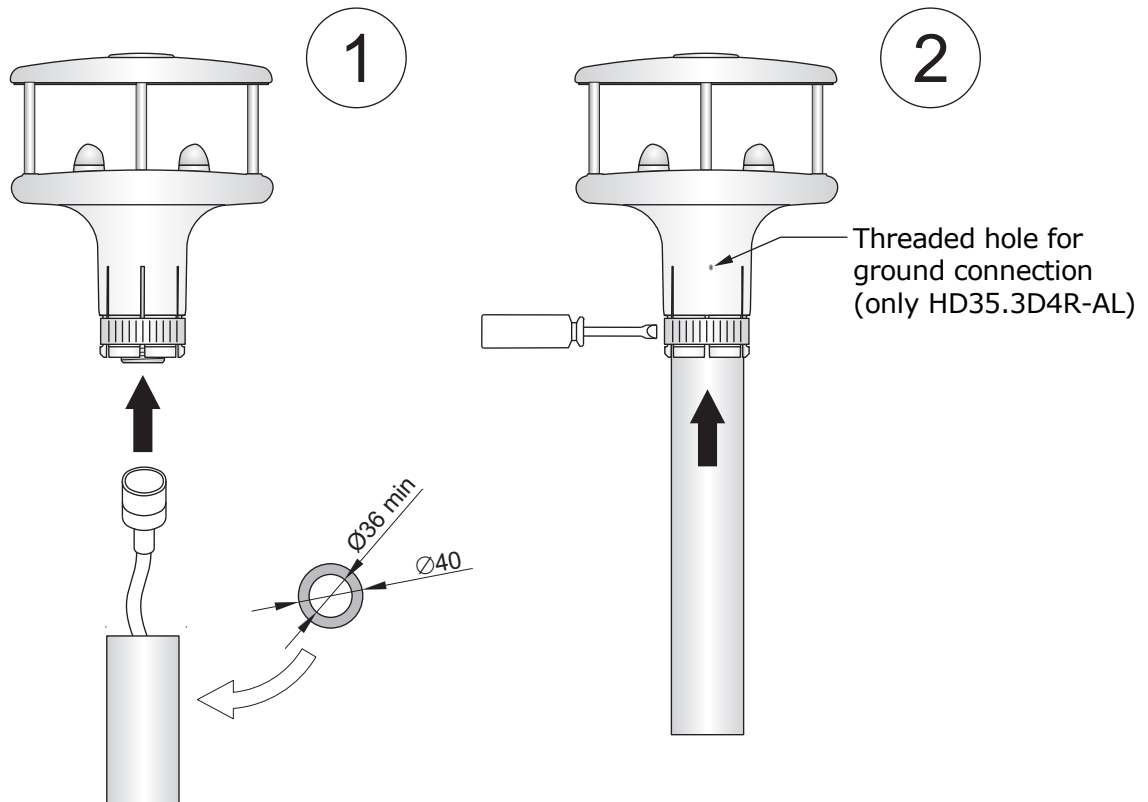

The support mast, having 40 mm maximum outer diameter and 36 mm minimum inner diameter, should be positioned on a stable surface and must be connected to ground.

The HD54.3D4R-AL model must be connected to ground by means of the threaded hole on the instrument body (see the figure above). Insert the cable lug of the ground cable into the fixing screw and tighten the screw to the instrument body.

The instrument should be installed vertically and in an open area, far from obstructions located in the vicinity that might alter the natural air flow. Any close objects (such as buildings, trees, pylons, etc.) should be at a distance equal to at least ten times their height.

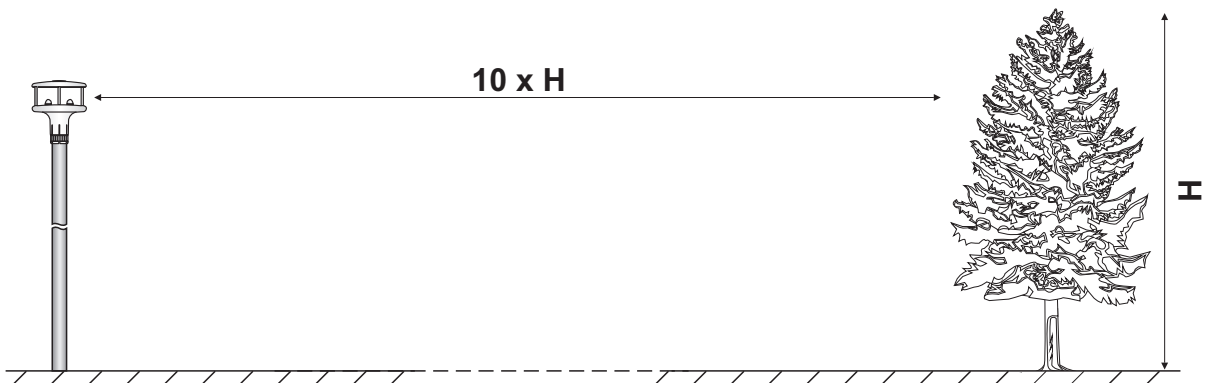

In the presence of close objects, it is advisable to place the instrument at a height of 10 m.

For open-space installations, the instrument can be installed using the **HD2005.20** (2 m) or **HD2005.20.1** (3 m) tripod.

If the instrument is installed on a building, the height of the instrument should be at least 1.5 times the minimum value between the height of the building and the roof longest diagonal.

5.1 ALIGNMENT OF THE INSTRUMENT

The case has a reference arrow at the bottom: align the arrow with the geographical **North**.

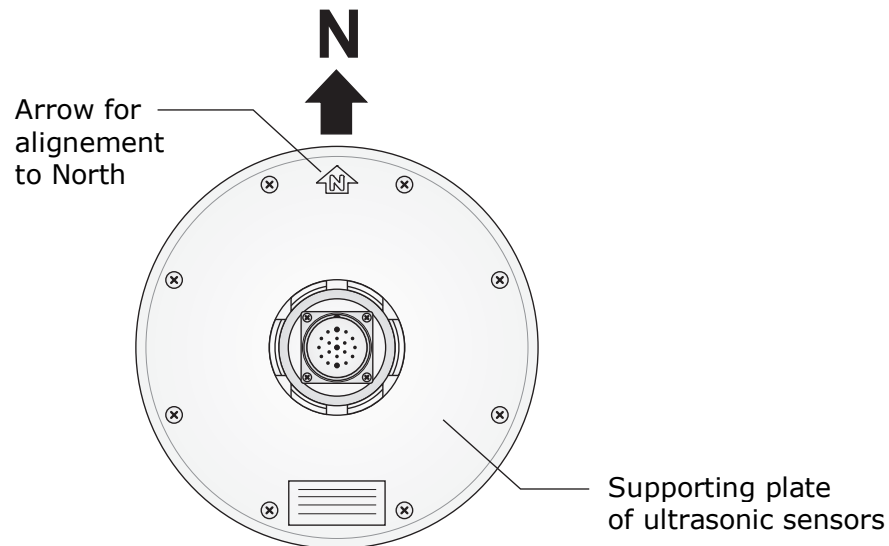

If a magnetic compass is used for alignment, take into account that the geographic North differs from the magnetic North indicated by the compass. The difference, named **magnetic declination**, depends on the area where the instrument was installed (for example, about 15° in North-America and less than 3° in Europe).

If wind speed and direction values are given in polar coordinates, 0° angle corresponds to a wind coming from North.

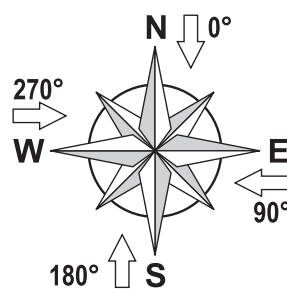

Take into account that the instrument measures the wind direction with respect to the reference arrow on the housing (the instrument is not equipped with a magnetic compass for the automatic compensation of the direction).

5.2 ELECTRICAL CONNECTIONS

All connections are performed through a 19-pole M23 male connector situated at the bottom of the instrument. The figure and the table below show numbers and function of the connector contacts and the corresponding colors of the optional **CP51.x** cable wires:

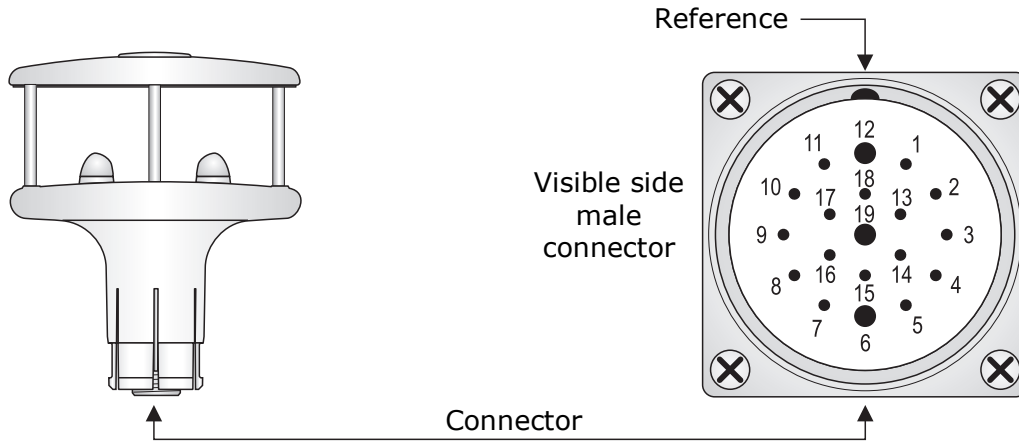

Connector pin number	CP51.x cable wire color	Symbol	Description
1	White/Red		Not used
2	White/Grey		Not used
3	Yellow/Brown	RX +	Serial receive (input) positive
4	Brown/Green	HEAT -	Heater power supply negative
5	Violet	HEAT +	Heater power supply positive (24 Vdc)
6	Brown	HEAT -	Heater power supply negative
7	Grey/Brown	HEAT +	Heater power supply positive (24 Vdc)
8	Yellow	GND	Serial ground (isolated from V -)
9	Grey	TX -	Serial transmission (output) negative "DATA -" main RS485 output
10	White/Yellow	AUX_B	"DATA +" auxiliary RS485 output (D+)
11	White	AUX_A	"DATA -" auxiliary RS485 output (D-)
12	Black	V -	Instrument power supply negative
13	Green	RX -	Serial receive (input) negative
14	Pink/Brown	OUT 1	Analog output 1 positive
15	Blue	GND	Analog ground (isolated from V -)
16	Red/Blue	OUT 2	Analog output 2 positive
17	White/Green	TX +	Serial transmission (output) positive "DATA +" main RS485 output
18	--		Not used
19	Red	V +	Instrument power supply positive (12...30 Vdc)
--	Grey/Red	SHIELD	Cable shield

5.2.1 RS232 SERIAL CONNECTION

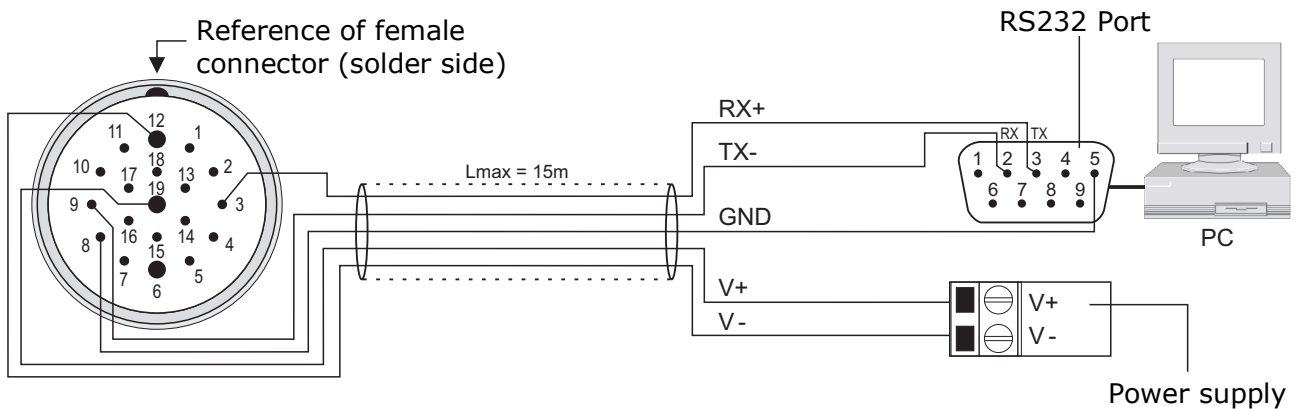

For RS232 connection, TX-, RX+ and serial GND signals (pin 9, 3 and 8 of M23 connector) are used, to be connected respectively to RX, TX and GND signals of RS232 port on PC (pin 2, 3 and 5 of 9-pole SubD connector). The length of RS232 cables should not exceed 15 m.

5.2.2 RS485 SERIAL CONNECTION

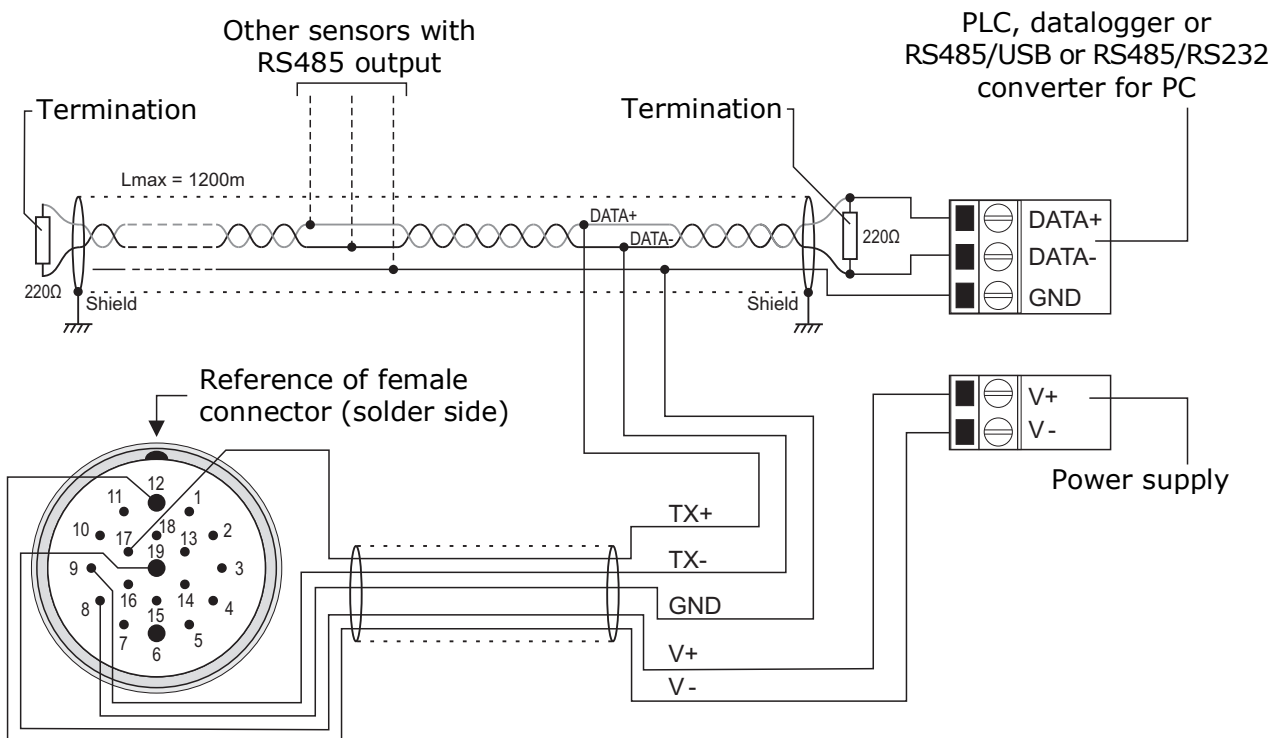

Thanks to RS485 connection, multiple instruments can be connected to a multi-point network. Instruments are connected in sequence through a twisted-pair shielded cable for signals and a third wire for ground.

Line terminations should be placed at the two ends of the network. The cable shield should be connected to both ends of the line.

The maximum number of devices that can be connected to the RS485 line (Bus) depends on the load characteristics of the devices to be connected. The RS485 standard requires that the total load does not exceed 32 unit loads. The load of an HD51.3D4R... anemometer is equal to $\frac{1}{4}$ of unit load. If the total load is greater than 32 unit loads, divide the network into segments and

add a signal repeater between a segment and the successive one. Line termination should be applied at both ends of each segment.

The maximum length of the cable depends on the transmission speed and the cable characteristics. Typically, the maximum length is 1200 m. The data line should be kept separated from any power lines in order to prevent interference with the transmitted signal.

Each instrument on the network is univocally identified by an address. **Multiple transmitters with the same address should not be placed on the network.**

If the instrument is connected to a data logger, the possibility to connect multiple sensors to the network depends on the data logger capacity to manage multiple sensors.

Before connecting the instrument to the network, configure address and Baud Rate (see chapter 6).

5.2.3 RS422 SERIAL CONNECTION

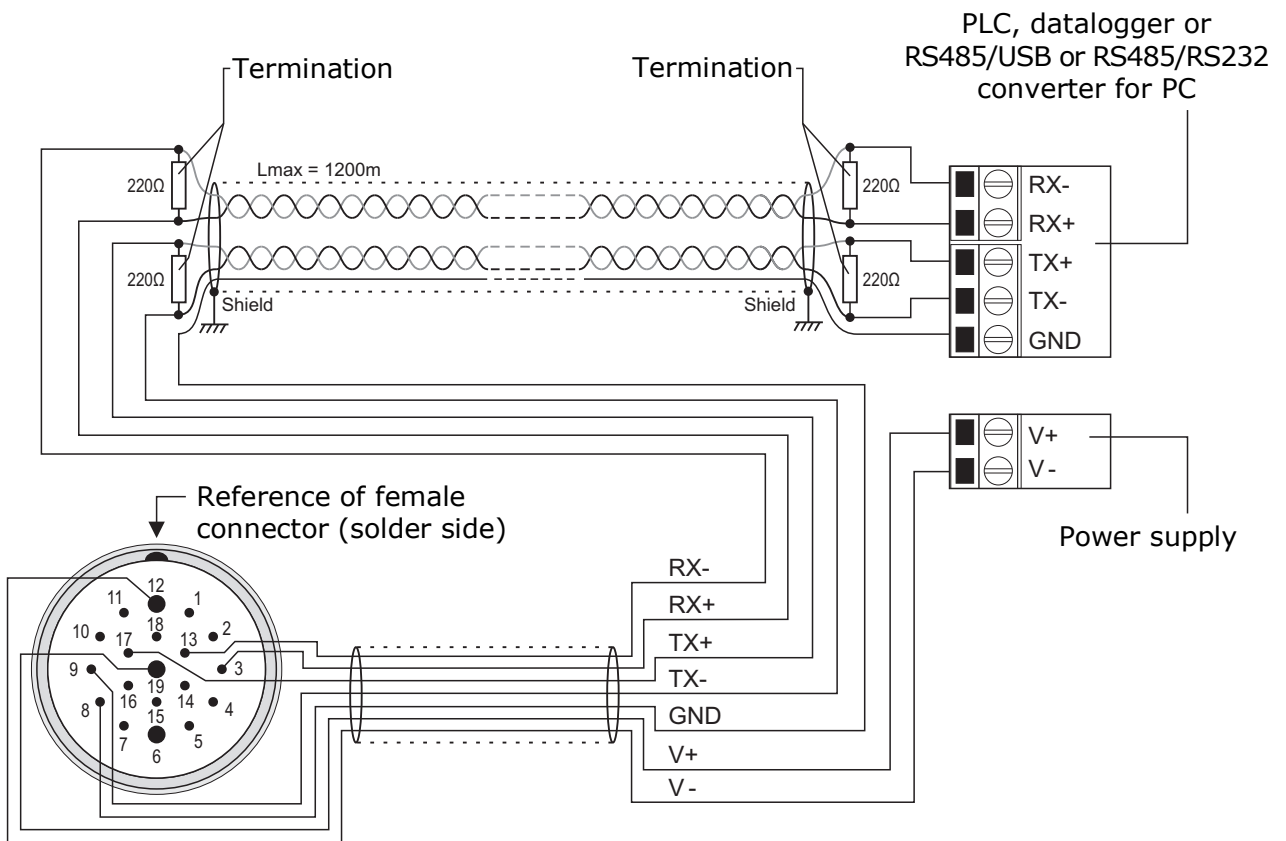

RS422 standard is used for point-to-point connection on long distances. The instrument is connected to a PC/data logger through a shielded cable with two twisted pairs for signals and an additional wire for ground. The extremities of the connections should end with line terminators.

The maximum length of the cable depends on the transmission speed and the cable characteristics. Typically, the maximum length is 1200 m. The data lines should be kept separated from any power lines in order to prevent interference with the transmitted signal.

Before connecting the instrument to the network, configure address and Baud Rate (see chapter 6).

5.2.4 ANALOG OUTPUTS CONNECTION

Connect the outputs according to one of the two schemes below, depending on the output type, current (standard) or voltage (on request), available in the instrument. **OUT 1** and **OUT 2** are associated to wind speed and direction respectively. In order to change the type of speed and direction measurements associated to the outputs (e.g., to associate to the outputs the U-V cartesian components), see chapter 6.

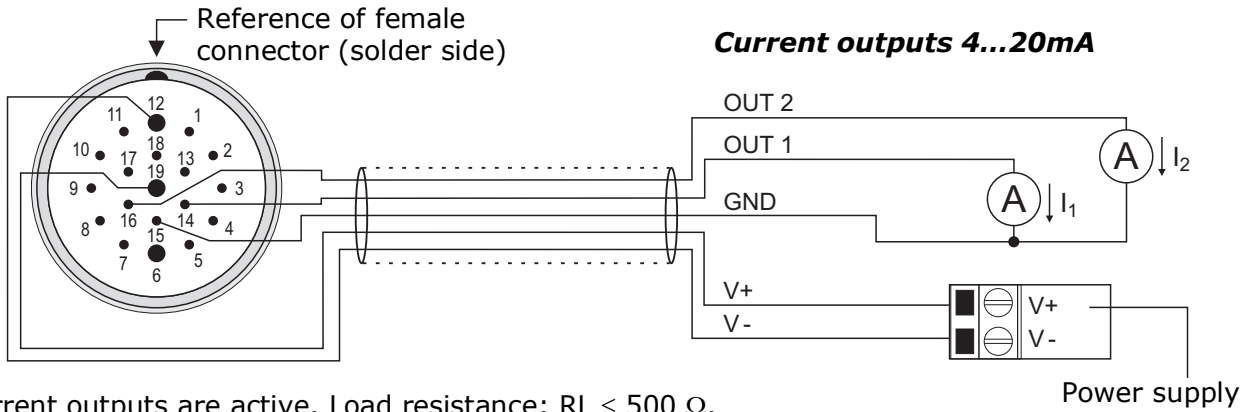

Current outputs are active. Load resistance: $R_L \leq 500 \Omega$.

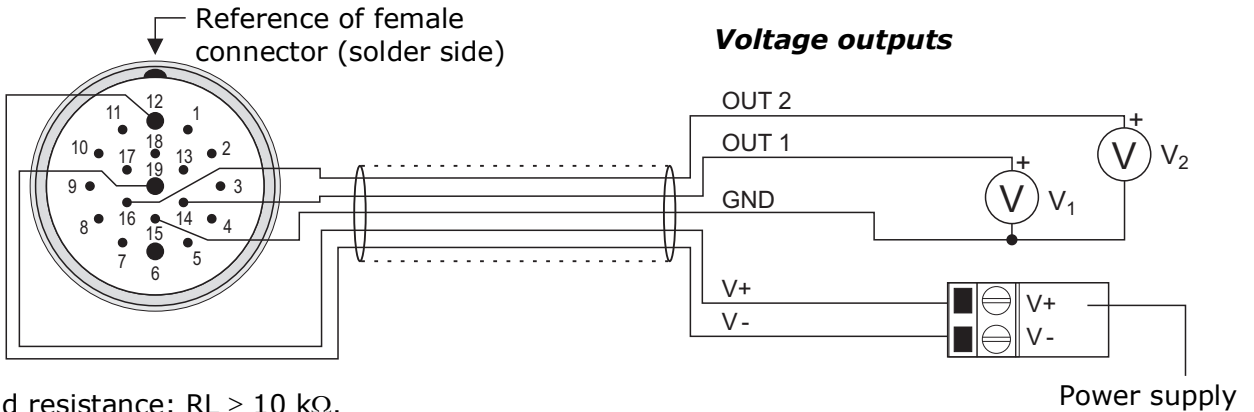

Load resistance: $R_L \geq 10 \text{ k}\Omega$.

5.2.5 CONNECTION OF HEATING SYSTEM

The heater power supply is separated from the instrument's main power supply.

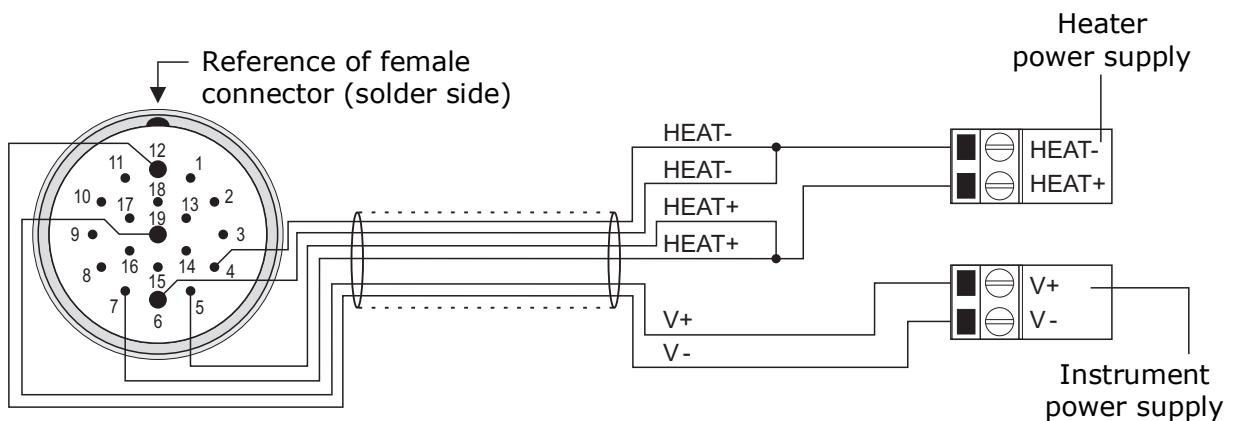

The heat circuit is switched on below $+4 \text{ }^\circ\text{C}$. After switching on, the heating is switched off when the temperature exceeds $+10 \text{ }^\circ\text{C}$.

5.2.6 AUXILIARY RS485 SERIAL OUTPUT CONNECTION

The auxiliary RS485 serial output can be used as an alternative to the main serial connection for connecting the instrument to the PC, for the configuration of the instrument via serial commands or the use of the **HD52.3D-S** application software.

The advantage of the auxiliary RS485 serial output is that it is always available to receive commands from the PC via a standard serial communication program or the **HD52.3D-S** application software (the main serial output, instead, is not available if it is busy with one of the operating protocols). Furthermore, the auxiliary RS485 serial output allows using long cables.

The auxiliary RS485 serial output does not work with the operating protocols (NMEA, MODBUS-RTU or ASCII proprietary).

For connecting the auxiliary RS485 serial output to the PC, the **optional RS51K** can be used. The kit includes the SWD10 power supply and the RS485/USB adapter with:

- screw terminals for the connection to the CP51... cable (not included);
- USB connector for the connection to the PC;
- jack connector for connecting the SWD10 power supply.

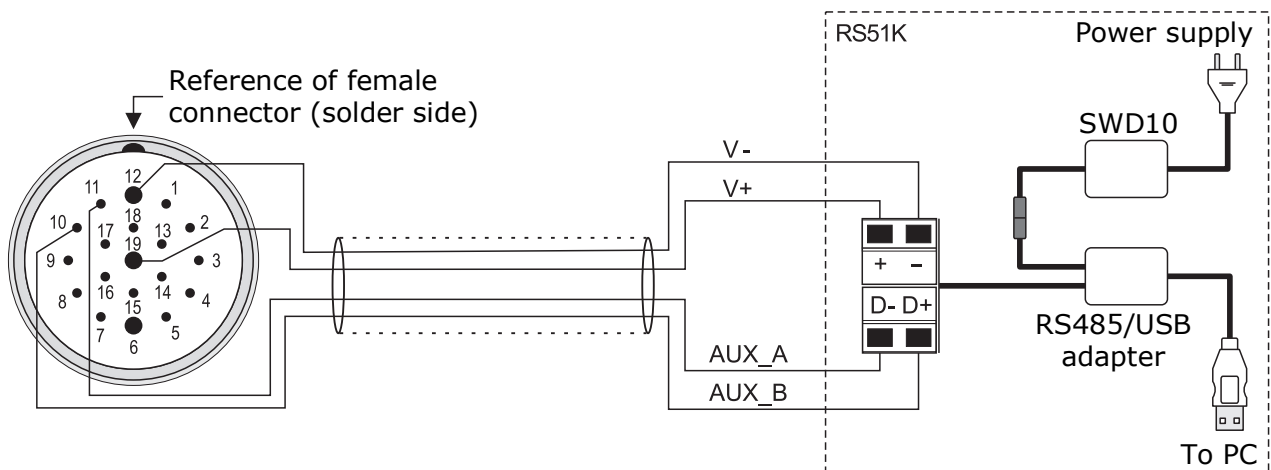

To use the **RS51K** kit, the drivers included in the HD52.3D-S software package, downloadable from Delta OHM website, should be installed in the PC (see the guide to USB drivers installation in the *Documentation* section of the software package).

5.3 SERIAL OUTPUT PROTOCOL

Unless otherwise requested, at the first power up the instrument main serial output starts in configuration mode and waits to receive the commands for setting the operating parameters (see chapter 6) or the connection with the **HD52.3D-S** application software.

In this case, in order to activate an operating protocol (NMEA, MODBUS-RTU or ASCII proprietary) it is necessary to set it with the appropriate serial command (CUMn, see chapter 6) or with the aid of the **HD52.3D-S** application software.

If the instrument is set up to work with an operating protocol, the protocol becomes active 10 seconds after power on (in the first 10 seconds the instrument waits for a possible command to enter configuration mode, as explained in chapter 6).

The auxiliary RS485 serial output is always in configuration mode.

6 CONFIGURATION

Configuration mode allows to read the instrument general info (firmware version, serial number, ...) and to set the instrument operation mode and operation parameters. The configuration of the instrument can be done in two ways:

- With the aid of **HD52.3D-S** application software (see the instructions of the software).
- By sending serial commands (listed in paragraph 6.1) via a standard communication program.

If a standard communication program is used, the program communication parameters should be set as follows:

- Baud rate = 115200
- Data bits = 8
- Parity = None
- Stop bits = 2
- Flow control = None

For the configuration, the instrument can be connected to the PC:

- Via **auxiliary RS485** (see paragraph 5.2.6 for the connection).
The auxiliary RS485 serial output is always in configuration mode and therefore it is always available to receive commands from the PC.
- Via **RS232** (see paragraph 5.2.1 for the connection).
The instrument can receive commands from the PC via RS232 only if it is in configuration mode (factory setting, unless otherwise requested).
If the instrument is not set in in configuration mode but in one of the available operating modes (NMEA, MODBUS-RTU or ASCII proprietary), to enter configuration mode it is necessary to send **within 10 seconds from power on** (if the instrument is already powered, disconnect and reconnect the power supply) the serial command @ (if a standard communication program is used) or the request of connection with the **HD52.3D-S** application software, if the application software is used.

6.1 SERIAL COMMANDS

Instrument control:

Command	Reply	Description
@	&	Allows entering configuration mode if the instrument is set up in an operating mode. It must be sent within 10 seconds from power on.
#	<i>Info on operating mode</i>	Exits from the configuration mode activated with the command @.

Operating Mode:

Command	Reply	Description
CUMn	&	Sets instrument in mode: <ul style="list-style-type: none"> ▪ Configuration if n=0 ▪ ASCII proprietary if n=2 ▪ NMEA if n=4 ▪ MODBUS-RTU if n=5 <i>Default</i> : Configuration (n=0)
RUM	& n	Reads mode set in the instrument

Note 1: after sending the CUMn command, the instrument remains in configuration mode. Power cycle the instrument to activate the set operating mode.

Parameters for ASCII proprietary mode:

Command	Reply	Description
CU2Bn	&	Sets Baud Rate for ASCII proprietary mode to: <ul style="list-style-type: none"> ▪ 9600 if n=3 ▪ 19200 if n=4 ▪ 38400 if n=5 ▪ 57600 if n=6 ▪ 115200 if n=7 <i>Default</i> : 115200 (n=7)
RU2B	& n	Reads Baud Rate setting for ASCII proprietary mode
CU2In	&	Sets interface for ASCII mode to: <ul style="list-style-type: none"> ▪ RS232 if n=0 ▪ RS485 if n=1 ▪ RS422 if n=2 <i>Default</i> : RS485 (n=1)
RU2I	& n	Reads interface setting for ASCII mode
CU2Mn	&	Sets parity and stop bits for ASCII mode to: <ul style="list-style-type: none"> ▪ 8N1 if n=0 [No parity, 1 stop bit] ▪ 8N2 if n=1 [No parity, 2 stop bits] ▪ 8E1 if n=2 [Even parity, 1 stop bit] ▪ 8E2 if n=3 [Even parity, 2 stop bits] ▪ 8O1 if n=4 [Odd parity, 1 stop bit] ▪ 8O2 if n=5 [Odd parity, 2 stop bits] The number of data bits is fixed to 8 <i>Default</i> : 8N2 (n=1)
RU2M	& n	Reads current setting of parity and stop bits for ASCII mode
CU1Dcccccc	&	Sets measurements order in the string sent in ASCII proprietary mode In the sequence cccccccccc, each character identifies a measurement according to the following correspondence: <ul style="list-style-type: none"> 0 ⇒ Barometric Pressure 5 ⇒ Wind speed (coordinates U,V) 7 ⇒ Wind speed (intensity) 8 ⇒ Wind Direction (Azimuth) G ⇒ Wind Gust (intensity and direction) S ⇒ Sound speed T ⇒ Sonic Temperature E ⇒ Errors <i>Default</i> : 780TE (see Note 2)
RU1D	& cccccccccc	Reads measurements order in the string sent in ASCII proprietary mode

Command	Reply	Description
CU2Rnnnn	&	Sets transmission interval of string with measurements in ASCII proprietary mode to nnnn seconds The interval should range within 1 and 3600 seconds <i>Default</i> : 1 second
RU2R	& nnnn	Reads transmission interval of string with measurements in ASCII proprietary mode

NOTE 2 : MEASUREMENTS ORDER

In the measurement string sent by the instrument in ASCII proprietary mode, measurements can be set in arbitrary order: one should simply indicate the desired order in the sequence of characters "cccccc" sent by the command C1UD. The sequence of characters "cccccc" can have a variable length up to a maximum of 16 characters.

Example: if the sequence of characters is set to 780, wind speed, wind direction and barometric pressure measurements will appear from left to right in the data string sent by the instrument.

If information on error conditions is requested (E character), three numbers with the following meaning will appear in the data string sent by the instrument:

1. *First number* = error code identifying the transducers and the type of error.
The number is composed by two digits. The first digit indicates the transducer that presents the error, according to the numeration indicated in the figure:

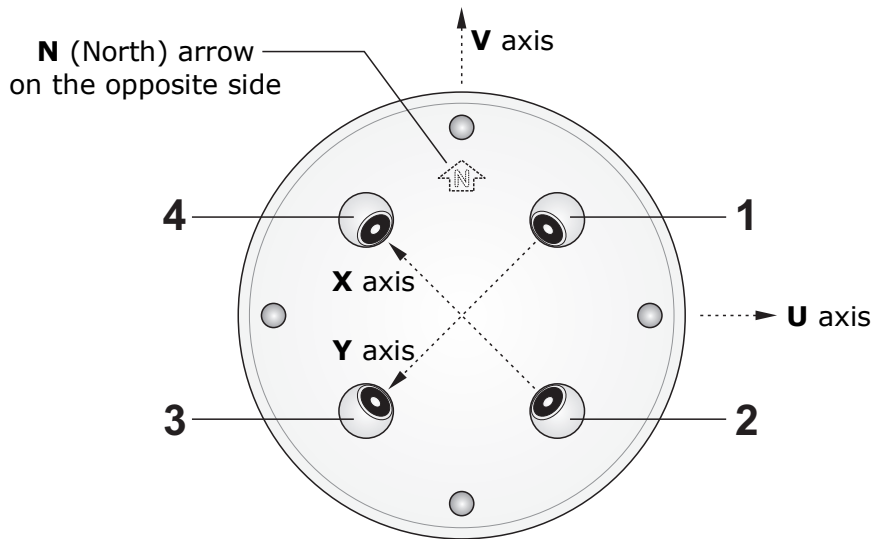

Digit 0 indicates that no errors are present in the ultrasonic transducers.

The second digit of the error code indicates the type of error: **0** = no errors; **1** = transducer broken, electric interruption, path obstruction; **Other** = codes reserved to technical service.

2. *Second number* = heating status: **0** = off, **1** = housing heating is on, **2** = housing heating and transducers heating are both on.
3. *Third number* = number of invalid measurements.

Example: if **21 0 2** appears in correspondence to the error condition in the data string sent by the instrument, it means that an error occurred in the transducer number 2, that the heating is turned off and that two measurements have been rejected due to the error occurrence.

Parameters for NMEA mode:

Command	Reply	Description
CU4Bn	&n	Sets Baud Rate for NMEA mode to: <ul style="list-style-type: none"> ▪ 2400 if n=1 ▪ 4800 if n=2 ▪ 9600 if n=3 ▪ 19200 if n=4 ▪ 38400 if n=5 ▪ 57600 if n=6 ▪ 115200 if n=7 <i>Default</i> : 4800 (n=2)
RU4B	&n	Reads Baud Rate setting for NMEA mode
CU4In	&n	Sets interface for NMEA mode to: <ul style="list-style-type: none"> ▪ RS232 if n=0 ▪ RS485 if n=1 ▪ RS422 if n=2 <i>Default</i> : RS485 (n=1)
RU4I	&n	Reads interface setting for NMEA mode
CU4Mn	&n	Sets parity and stop bits for NMEA mode to: <ul style="list-style-type: none"> ▪ 8N1 if n=0 [No parity, 1 stop bit] ▪ 8N2 if n=1 [No parity, 2 stop bits] ▪ 8E1 if n=2 [Even parity, 1 stop bit] ▪ 8E2 if n=3 [Even parity, 2 stop bits] ▪ 8O1 if n=4 [Odd parity, 1 stop bit] ▪ 8O2 if n=5 [Odd parity, 2 stop bits] The number of data bits is fixed to 8 <i>Default</i> : 8N1 (n=0)
RU4M	&n	Reads current setting of parity and stop bits for NMEA mode
CU4Rnnn	&n	Sets transmission interval of string with measurements in NMEA mode to nnn seconds The interval should range within 1 and 255 seconds <i>Default</i> : 1 second
RU4R	&nnn	Reads setting of transmission interval of string with measurements in NMEA mode

Parameters for MODBUS-RTU mode:

Command	Reply	Description
CU5Annn	&	Sets MODBUS address to nnn The address should range within 1 and 247 <i>Default</i> : 1
RU5A	& nnn	Reads the MODBUS address setting
CU5Bn	&	Sets the Baud Rate for MODBUS mode to: <ul style="list-style-type: none"> ▪ 9600 if n=3 ▪ 19200 if n=4 ▪ 38400 se n=5 ▪ 57600 se n=6 ▪ 115200 se n=7 <i>Default</i> : 19200 (n=4)
RU5B	& n	Reads Baud Rate setting for MODBUS mode
CU5In	&	Sets interface for MODBUS mode to: <ul style="list-style-type: none"> ▪ RS232 if n=0 ▪ RS485 if n=1 ▪ RS422 if n=2 <i>Default</i> : RS485 (n=1) Note: with RS232 option you can connect to PC or datalogger 1 instrument only; option useful to do tests without RS232/RS485 conversion.
RU5I	& n	Reads interface setting for MODBUS mode
CU5Mn	&	Sets parity and stop bits for MODBUS mode to: <ul style="list-style-type: none"> ▪ 8N1 if n=0 [No parity, 1 stop bit] ▪ 8N2 if n=1 [No parity, 2 stop bits] ▪ 8E1 if n=2 [Even parity, 1 stop bit] ▪ 8E2 if n=3 [Even parity, 2 stop bits] ▪ 8O1 if n=4 [Odd parity, 1 stop bit] ▪ 8O2 if n=5 [Odd parity, 2 stop bits] The number of bits is fixed to 8 <i>Default</i> : 8E1 (n=2)
RU5M	& n	Reads the setting of parity and stop bits for MODBUS mode
CU5Wn	&	Sets waiting time after transmission in MODBUS mode to: <ul style="list-style-type: none"> ▪ Immediate reception if n=0 (violates protocol) ▪ Waiting 3.5 characters if n=1 (respects protocol) <i>Default</i> : Waiting 3.5 characters (n=1)
RU5W	& n	Reads current setting of waiting time after transmission in MODBUS mode

Units of measurement:

Command	Reply	Description
CGUVn	&	Sets measuring unit of wind speed: <ul style="list-style-type: none"> ▪ m/s if n=1 ▪ cm/s if n=2 ▪ km/h if n=3 ▪ knot if n=4 ▪ mph if n=5 <i>Default</i> : m/s (n=1)
RGUV	n	Reads the wind speed measuring unit set in the instrument
CGUTn	&	Sets temperature measuring unit: <ul style="list-style-type: none"> ▪ °C if n=1 ▪ °F if n=2 <i>Default</i> : °C (n=1)
RGUT	n	Reads the temperature measuring unit set in the instrument
CGUPn	&	Sets pressure measuring unit: <ul style="list-style-type: none"> ▪ mbar if n=1 [Note:1 mbar=1 hPa] ▪ mmHg if n=2 ▪ inchHg if n=3 ▪ mmH₂O if n=4 ▪ inchH₂O if n=5 ▪ atm if n=6 <i>Default</i> : mbar (n=1)
RGUP	n	Reads the pressure measuring unit set in the instrument

General parameters:

Command	Reply	Description
CGHn	&	Enables/disables heating: <ul style="list-style-type: none"> ▪ Disables if n=0 ▪ Enables if n=1 <i>Default</i> : Enabled (n=1)
RGH	n	Reads heating enabling state set in the instrument
CWCnnnn	&	Sets wind speed threshold to nnnn value (in hundredths of m/s) Value should range within 0 and 100 hundredths of m/s (= 0...1 m/s) <i>Default</i> : 20 (= 0.2 m/s) (see Note 3)
RWC	& nnnn	Reads the wind speed threshold value set in the instrument (in hundredths of m/s)
CWaLnnn	&	Sets time interval for the calculation of average speed and average direction to nnn value Value should range within 1 and 600 s <i>Default</i> : 1 s

Command	Reply	Description
RWaL	& nnn	Reads the time interval for the calculation of average speed and average direction set in the instrument
CWaMn	&	Sets the method for the calculation of average speed and average direction: <ul style="list-style-type: none"> ▪ If n=0: scalar average. ▪ If n=1: vector average. <i>Default</i> : vector average (n=1) (see Note 4)
RWaM	& n	Reads the method for the calculation of the average speed and average direction set in the instrument
CWgLnnn	&	Sets time interval for the calculation of averages in Wind Gust measurement to nnn value Value should range within 1 and 100 s <i>Default</i> : 3 s (standard WMO value) (see Note 6)
RWgL	& nnn	Reads the time interval for the calculation of averages in Wind Gust measurement set in the instrument
CWgMn	&	Sets the method for the calculation of averages in Wind Gust measurement: <ul style="list-style-type: none"> ▪ scalar average if n=0 ▪ vector average if n=1 <i>Default</i> : vector average (n=1) <i>Note: see the description of the command CWaMn for the meaning of scalar average and vector average.</i>
RWgM	& n	Reads the method for the calculation of averages in Wind Gust measurement set in the instrument
CWgOnnn	&	Sets time interval for detecting the maximum of the averages in Wind Gust measurement to nnn value Value should range within 1 and 600 s <i>Default</i> : 60 s (see Note 6)
RWgO	& nnn	Reads the time interval for detecting the maximum of the averages in Wind Gust measurement set in the instrument
cor n	cor	Sets the measurement rate to n measurements/s Value should range within 1 and 4 <i>Default</i> : 4
ror	n samples per second	Reads the measurement rate set in the instrument

NOTE 3 : WIND SPEED THRESHOLD VALUE

If the wind speed is very low, the determination of the direction can result inaccurate. The instrument allows setting the threshold value of speed below which the direction value is frozen on the last acquired value.

NOTE 4 : SCALAR AVERAGE AND VECTOR AVERAGE

Scalar average: the average intensity is calculated as average of intensities. For the calculation of the average direction, also called "prevailing direction", the velocity **vector** (unit vector having the same direction of the velocity vector) is considered for each measurement, and the versor coordinates along the measurement axes are calculated, then the average of the coordinates along each axis is calculated. The two average coordinates determine the average versor and therefore the average direction. The average direction is expressed according to the extended characteristic for the analog output (see **Note 5**).

Vector average: for each measurement, the coordinates of the velocity vector along the measurement axes are calculated and then the average of the coordinates along each axis is calculated. The average intensity and the average direction are those determined by the two average coordinates.

NOTE 5 : WIND DIRECTION EXTENDED CHARACTERISTIC

With 0÷359.9° wind direction measuring range, the analog output continues to oscillate between maximum and minimum scale if the direction continues to slightly fluctuate around 0°:

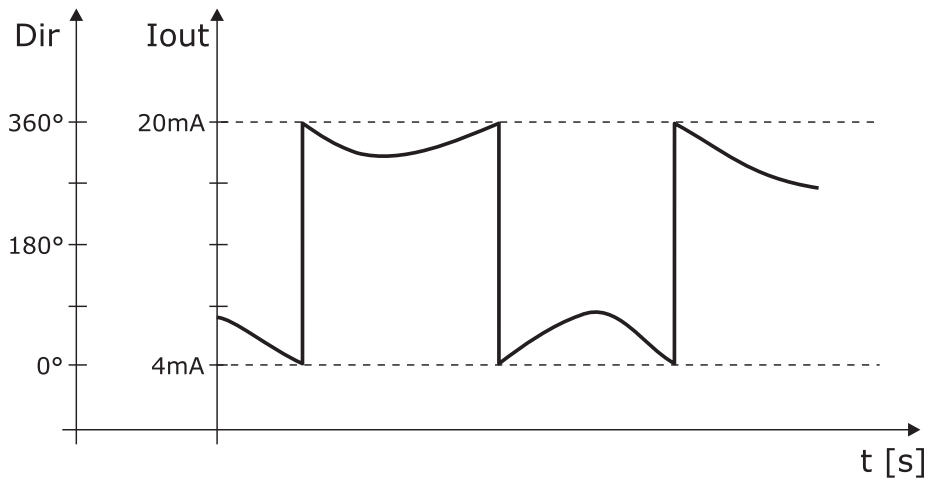

This effect can be reduced through the extended ("wrap-around") characteristic of wind direction. In this mode, the wind direction is considered as corresponding to 0÷539.9° range instead of 0÷359.9°. The wide output fluctuation occurs the first time that the wind direction goes from 0 to 359.9°; if later the "physical" direction goes back to 0°, the analog output will always remain around 360°. Using the extended characteristic, the behavior of the above graph changes into the following:

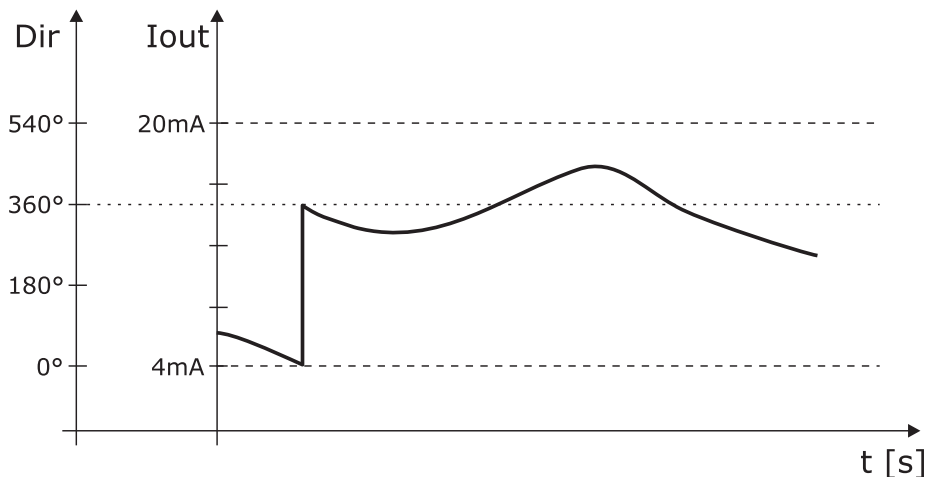

If 539.9° value is exceeded in extended mode, the output goes to the value corresponding to 180°.

The table below shows the correspondence between the value of the analog output and the direction of the wind in the two modes.

Wind direction	4...20mA output		0...1V output		0...5V output		0...10V output	
	standard	extended	standard	extended	standard	extended	standard	extended
0°	4.00	4.00	0.00	0.00	0.00	0.00	0.00	0.00
180°	12.00	9.33	0.50	0.33	2.50	1.67	5.00	3.33
360°	20.00	14.67	1.00	0.67	5.00	3.33	10.00	6.67
540°	--	20.00	--	1.00	--	5.00	--	10.00

NOTE 6 : WIND GUST MEASUREMENT

The Wind Gust measurement is determined as follows:

- the wind speed averages (according to the method set with the **CWgM** command, by default vector averages) in a time interval equal to that set with the **CWgL** command (by default 3 seconds) are calculated continuously;
- the maximum value of the averages calculated in the previous point is detected over a time interval equal to that set with the **CWgO** command (by default 60 seconds); the maximum value detected is the measure of Wind Gust.

Analog outputs:

Command	Reply	Description
RAT	& n	<p>Reads the analog output type:</p> <ul style="list-style-type: none"> ▪ 4...20/0...20 mA if n=0 ▪ 0...1 V if n=1 ▪ 0...5 V if n=2 ▪ 0...10 V if n=3
CAFxnn	&	<p>Sets offset and direction of the analog output x (x=1 or 2) to:</p> <ul style="list-style-type: none"> ▪ Standard if nn=00 [ex. 4...20mA, 0...1V, 0...5V, 0...10V] ▪ Without offset if nn=01 [ex. 0...20mA] ▪ With offset if nn=02 [ex. 0.2...1V, 1...5V, 2...10V] ▪ Inverted if nn=04 [ex. 20...4mA, 1...0V, 5...0V, 10...0V] ▪ Inverted without offset if nn=05 [ex. 20...0mA] ▪ Inverted with offset if nn=06 [ex. 1...0.2V, 5...1V, 10...2V] <p><i>Default : Standard (nn=00)</i></p>
RAFx	& nn	<p>Reads offset and direction setting of the analog output x (x=1 or 2)</p>
CAMn	&	<p>Association of the analog outputs:</p> <ul style="list-style-type: none"> ▪ If n= 0: Output 1 = Mean wind speed Output 2 = Mean wind direction (with extended characteristic if the average is scalar) ▪ If n= 1 (see Note 7): Output 1 = Instant wind speed component along V-axis Output 2 = Instant wind speed component along U-axis ▪ If n= 2 (Tunnel mode, see Note 8): Output 1 = Instant wind speed component along the direction indicated by the arrow on the instrument case Output 2 = Instant wind direction referred to the direction indicated by the arrow on the instrument case <p><i>Default : n=0</i></p>
RAM	& n	<p>Reads the association of analog outputs</p>

Command	Reply	Description
CAHn	&	Associates full scale of wind speed analog output to: <ul style="list-style-type: none"> ▪ 5 m/s if n=0 ▪ 10 m/s if n=1 ▪ 15 m/s if n=2 ▪ 20 m/s if n=3 ▪ 25 m/s if n=4 ▪ 30 m/s if n=5 ▪ 35 m/s if n=6 ▪ 40 m/s if n=7 ▪ 45 m/s if n=8 ▪ 50 m/s if n=9 ▪ 55 m/s if n=10 ▪ 60 m/s if n=11 ▪ 65 m/s if n=12 ▪ 70 m/s if n=13 ▪ 75 m/s if n=14 ▪ 80 m/s if n=15 ▪ 85 m/s if n=16 ▪ 90 m/s if n=17 <i>Default : 75 m/s (n=14)</i>
RAH	& n	Reads the value corresponding to the wind speed analog output full scale

NOTA 7 : U,V COMPONENTS

By selecting the U and V components, the speed value associated to the initial scale of the two analog outputs is equal to the opposite of the speed value associated to the full scale of the outputs.

For example, if the speed full scale value is set to 60 m/s, the speed range associated to the analog outputs is -60...+60 m/s.

NOTA 8 : TUNNEL MODE

The arrow on the instrument case should be aligned with the direction of the tunnel.

The output 2 is set to full scale value if the wind blows in the direction of the arrow, and to initial scale value if the wind blows in the opposite direction.

The initial scale of output 1 is associated to the speed value opposite to that associated to the output full scale.

Instrument information:

Command	Reply	Description
G1	&VPnn.nn yyyy/mm/dd	Version and date of firmware
RGS	&nnnnnnnn	Serial number of instrument
RGI	&ccc...ccc	User code
CGIccc...ccc	&	Sets user code to ccc...ccc (max. 34 characters)

7 ASCII PROPRIETARY MODE

In ASCII proprietary mode, the instrument sends automatically the acquired measurements at regular intervals. The interval is factory-set to 1 second and is configurable from 1 to 3600 seconds. To change the interval, you should enter in configuration mode and send the command **CU2Rnnnn**, where nnnn indicates the interval value in seconds (see chapter 6 for details regarding the setting of operation parameters).

Communication parameters should be set in your PC as follows:

- Baud rate: same as the setting in the instrument (default = 115200)
- Data bits: 8
- Parity: same as the setting in the instrument (default = None)
- Stop bits: same as the setting in the instrument (default = 2)

The instrument sends measurements in the following format:

<M1><M2>...<Mn><CR><LF>

with <M1><M2>...<Mn> = values of the first, second,..., nth measurement

<CR> = ASCII character *Carriage Return*

<LF> = ASCII character *Line Feed*

Fields <M1><M2>...<Mn> consist of 8 characters each. Measurement values are justified right; spaces can be added to the left margin of the values to obtain the 8 character length requested by the fields.

The sequence of the measurement values <M1><M2>...<Mn> is configurable (command **CU1Dcccccc**, see chapter 6).

EXAMPLE

Supposing that the instrument measures the following values (the measuring unit is not considered, being not output by the instrument): M1=28.30, M2=359.3, M3=998.3, the data string sent by the instrument takes the form:

28.30 359.3 998.3<CR><LF>

8 NMEA MODE

NMEA protocol, mainly used in the nautical field and in satellite-based navigation systems, specifies that only one of the devices connected can send data, while the others can only act as recipients.

In NMEA mode, the instrument sends automatically the acquired measurements at regular intervals. The interval is factory-set to 1 second and can be configured within 1 and 255 seconds. To change the interval you should access the configuration mode and send **CU4Rnnn** command, where nnn indicates the interval value in seconds (see chapter 6 for details regarding the setting of operation parameters).

Communication parameters should be set in the PC or data logger as follows:

- Baud rate: same as the setting in the instrument (default = 4800)
- Data bits: 8
- Parity: same as the setting in the instrument (default = None)
- Stop bits: same as the setting in the instrument (default = 1)

The instrument is compatible with NMEA 0183 V4.00 protocol.

The protocol establishes that data are sent in the following format:

\$<Prefix>,<Data>*<hh><CR><LF>

with <Prefix> = field consisting in 5 alphanumeric characters: the first two indicate the type of transmitting device, the other three indicate the type of transmitted data
 <Data> = values measured by the instrument, separated by commas
 <hh> = checksum, consisting in two hexadecimal characters
 <CR> = character ASCII *Carriage Return*
 <LF> = character ASCII *Line Feed*

The checksum is calculated by performing the exclusive OR of all characters ranging within \$ and * symbols. The 4 most significant bits and the 4 less significant bits of the result are converted in hexadecimal. The hexadecimal value corresponding to the most significant bits is transmitted as the first.

The instrument regularly sends a string in the following general format requested by the protocol:

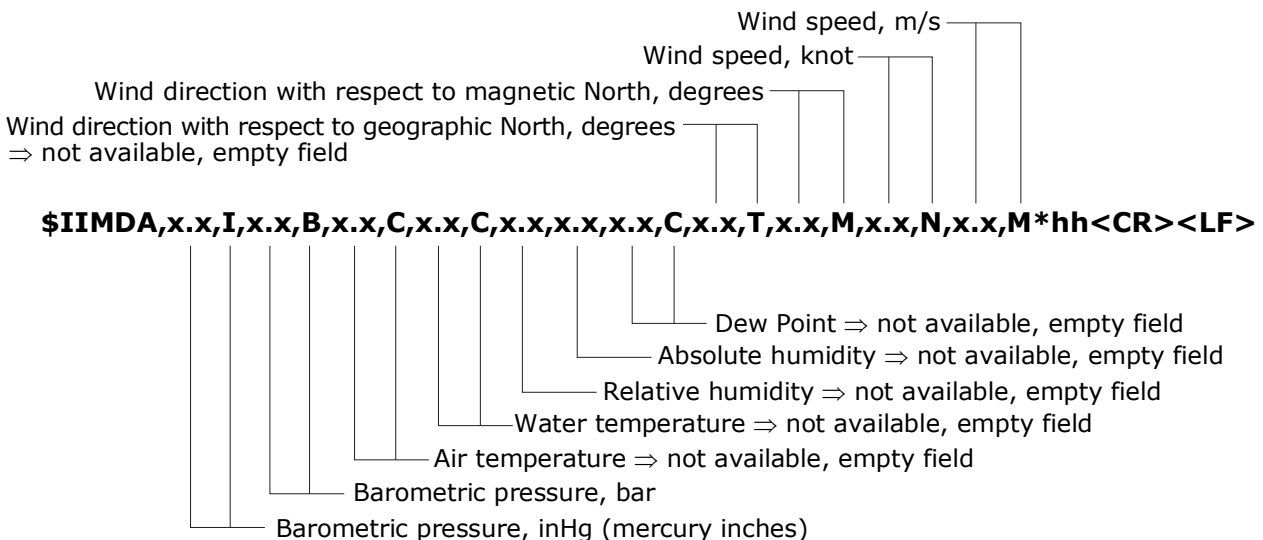

The fields related to quantities not measured by the instrument are empty (multiple consecutive commas appear to indicate the missing fields).

The previous string is followed by a second string (\$IIXDR...) provided for measurements not implemented in these instruments.

EXAMPLE

Suppose that there are the following environmental conditions:

- Wind speed = 5.60 m/s (=10.88 knot)
- Wind direction with respect to magnetic North = 38.7°
- Barometric pressure = 1014.9 hPa (= 30.0 inHg)

The string sent by the instrument is:

```
$IIMDA,30.0,I,1.0149,B,,C,,C,,,,C,,T,38.7,M,10.88,N,5.60,M*34<CR><LF>
```

For additional information regarding the protocol, visit the site "www.nmea.org".

9 MODBUS-RTU MODE

In MODBUS-RTU mode, the instrument sends the acquired measurements only if specifically requested by the PC, PLC or data logger.

Communication parameters should be set in the PC or data logger as follows:

- Baud rate: same as the setting in the instrument (default = 19200)
- Data bits: 8
- Parity: same as the setting in the instrument (default = even)
- Stop bits: same as the setting in the instrument (default = 1)

MEASUREMENTS READING (function **04h**)

The Modbus function code 04h (Read Input Registers) allows reading the values measured by the instrument. The following table lists the Input Registers available.

Modbus Input Registers

Register number	Quantity	Format
1	Instantaneous wind speed (x100)	unsigned 16 bits
2	Instantaneous wind direction in degrees (x10)	unsigned 16 bits
3	Sonic temperature measured by the transducers pair of the X axis (x10)	16 bits
4	Sonic temperature measured by the transducers pair of the Y axis (x10)	16 bits
5	Average of the two sonic temperatures measured by the two transducers pairs (x10)	16 bits
8	Barometric pressure (x1000 if the unit of measurement is atm, x10 in the other cases)	unsigned 16 bits
11	Average wind speed (x100)	unsigned 16 bits
12	Average wind direction in degrees (x10)	unsigned 16 bits
15	Wind direction in degrees (x10) with extended feature (see page 21)	unsigned 16 bits
16	Wind speed (x100) along V-axis	unsigned 16 bits
17	Wind speed (x100) along U-axis	unsigned 16 bits
18	Status register bit0=1 ⇒ Speed measurement error bit1=1 ⇒ Not used bit2=1 ⇒ Not used bit3=1 ⇒ Not used bit4=1 ⇒ Pressure measurement error bit5=1 ⇒ Not used	unsigned 16 bits
19	Wind speed unit of measurement 0 ⇒ m/s 3 ⇒ knot 1 ⇒ cm/s 4 ⇒ mph 2 ⇒ km/h	unsigned 16 bits
20	Temperature unit of measurement 0 ⇒ °C 1 ⇒ °F	unsigned 16 bits

Register number	Quantity	Format
21	Atm. pressure unit of measurement 0 ⇒ mbar (=hPa) 3 ⇒ mmH ₂ O 1 ⇒ mmHg 4 ⇒ inchH ₂ O 2 ⇒ inchHg 5 ⇒ atm	unsigned 16 bits
22	Wind Gust intensity (x100)	unsigned 16 bits
23	Wind Gust direction in degrees (x10)	unsigned 16 bits

Note: for quantities with configurable measurement unit, the measurement value is expressed in the unit set in the instrument.

For additional information regarding the protocol, visit the site "www.modbus.org".

10 INSTRUMENT STORAGE

Instrument storage conditions:

- Temperature: -40...+65 °C.
- Humidity: less than 90 %RH no condensation.
- In storing, avoid locations where:
 - There is a high humidity level.
 - The instrument is exposed to direct sunlight.
 - The instrument is exposed to a high temperature source.
 - There are high vibration levels.
 - There is presence of vapor, salt and/or corrosive gas.

11 SAFETY INSTRUCTIONS

General safety instructions

The instrument has been manufactured and tested in accordance with the safety standard EN61010-1:2010 "Safety requirements for electrical equipment for measurement, control and laboratory use" and has left the factory in perfect safety technical conditions.

The instrument proper operation and operating safety can be ensured only if all standard safety measures as well as the specific measures described in this manual are followed.

The instrument proper operation and operating safety can be ensured only in the climatic conditions specified in this manual.

Do not use the instrument in places where there are:

- Rapid ambient temperature variations that may cause condensation.
- Corrosive or flammable gases.
- Direct vibrations or shocks to the instrument.
- High-intensity electromagnetic fields, static electricity.

If the instrument is moved from a cold place to a hot one, or vice versa, condensation formation can cause an instrument malfunction. In this case, you will have to wait for the instrument temperature to reach ambient temperature before turning the instrument on.

User obligations

The instrument operator shall follow the directives and regulations below that refer to the treatment of dangerous materials:

- EEC directives on workplace safety
- National low regulations on workplace safety
- Accident prevention regulations

12 ORDERING CODES

- HD51.3D4R** 2-axis ultrasonic static anemometer. Measurement of wind speed and direction, U-V Cartesian components of wind speed, Wind Gust and barometric pressure. Isolated RS232, RS485, and RS422 serial outputs. **NMEA, MOD-BUS-RTU** and ASCII proprietary communication protocols. Two analog outputs for wind speed and direction, factory-configurable within 4÷20 mA (**standard**), 0...1 V, 0...5 V or 0...10 V (**to be specified when ordering**). Equipped with **heater**. Operating temperature -40...+60 °C. Instrument power supply 12...30 Vdc. Heater power supply 24 Vdc. Housing in ASA. Installation on mast Ø 40 mm external and Ø 36 mm internal. Input with 19-pole M23 male connector and 19-pole M23 female free connector. The **HD52.3D-S** software, for instrument configuration and monitor, downloadable from Delta OHM website is included. **CP51... cable on request.**
- HD51.3D4R-AL** 2-axis ultrasonic static anemometer. Measurement of wind speed and direction, U-V Cartesian components of wind speed, Wind Gust and barometric pressure. Isolated RS232, RS485, and RS422 serial outputs. **NMEA, MOD-BUS-RTU** and ASCII proprietary communication protocols. Two analog outputs for wind speed and direction, factory-configurable within 4÷20 mA (**standard**), 0...1 V, 0...5 V or 0...10 V (**to be specified when ordering**). Equipped with an **enhanced heater** for rapid defrosting. Operating temperature -40...+60 °C. Instrument power supply 12...30 Vdc. Heater power supply 24 Vdc. Housing in **anodized aluminum alloy**. Installation on mast Ø 40 mm external and Ø 36 mm internal. Input with 19-pole M23 male connector and 19-pole M23 female free connector. The **HD52.3D-S** software, for instrument configuration and monitor, downloadable from Delta OHM website is included. **CP51... cable on request.**

ACCESSORIES

- CP51...** Connecting cable with 19-pole M23 female free connector on one end, open wires on the other. Available lengths: 5 m (CP51.5), 10 m (CP51.10), 15 m (CP51.15), 20 m (CP51.20), 30 m (CP51.30), 50 m (CP51.50) and 75 m (CP51.75).
- RS51K** Kit for connecting the anemometer RS485 auxiliary output to a PC. It includes the SWD10 power supply and the RS485/USB adapter with:
- screw terminals for the connection to the CP51... cable (not included);
 - USB connector for the connection to the PC;
 - jack connector for connecting the SWD10 power supply.
- HD52.30K** Birds spikes.
- HD2005.20** Tripod with adjustable legs for installing environmental sensors. Material: anodized aluminum. Max. height 2 m. It can be fixed on a flat base with screws or to the ground with pegs. Foldable legs for the transport.
- HD2005.20.1** Tripod with adjustable legs for installing environmental sensors. Material: anodized aluminum. Max. height 3 m. It can be fixed on a flat base with screws or to the ground with pegs. Foldable legs for the transport.
- CP52.C** Additional 19-pole M23 female free connector.

DELTA OHM metrology laboratories LAT N° 124 are ISO/IEC 17025 accredited by ACCREDIA for Temperature, Humidity, Pressure, Photometry/Radiometry, Acoustics and Air Velocity. They can supply calibration certificates for the accredited quantities.

NOTES

NOTES

NOTES

**DICHIARAZIONE DI CONFORMITÀ UE
EU DECLARATION OF CONFORMITY****Delta Ohm S.r.L. a socio unico – Via Marconi 5 – 35030 Caselle di Selvazzano – Padova – ITALY**Documento Nr. / Mese.Anno: **5105 / 05.2018**
Document-No. / Month.Year :

Si dichiara con la presente, in qualità di produttore e sotto la propria responsabilità esclusiva, che i seguenti prodotti sono conformi ai requisiti di protezione definiti nelle direttive del Consiglio Europeo:

*We declare as manufacturer herewith under our sole responsibility that the following products are in compliance with the protection requirements defined in the European Council directives:*Codice prodotto: **HD51.3D4R / HD51.3D4R-AL**
Product identifier :Descrizione prodotto: **Anemometri a ultrasuoni**
Product description : **Ultrasonic anemometers**I prodotti sono conformi alle seguenti Direttive Europee:
The products conform to following European Directives:

Direttive / Directives	
2014/30/EU	Direttiva EMC / EMC Directive
2014/35/EU	Direttiva bassa tensione / Low Voltage Directive
2011/65/EU	RoHS / RoHS

Norme armonizzate applicate o riferimento a specifiche tecniche:
Applied harmonized standards or mentioned technical specifications:

Norme armonizzate / Harmonized standards	
EN 61010-1:2010	Requisiti di sicurezza elettrica / Electrical safety requirements
EN 61326-1:2013	Requisiti EMC / EMC requirements
EN 50581:2012	RoHS / RoHS

Il produttore è responsabile per la dichiarazione rilasciata da:
The manufacturer is responsible for the declaration released by:

Johannes Overhues

Amministratore delegato
Chief Executive Officer

Caselle di Selvazzano, 08/05/2018

Questa dichiarazione certifica l'accordo con la legislazione armonizzata menzionata, non costituisce tuttavia garanzia delle caratteristiche.

This declaration certifies the agreement with the harmonization legislation mentioned, contained however no warranty of characteristics.

GUARANTEE



Member of GHM GROUP

TERMS OF GUARANTEE

All DELTA OHM instruments are subject to accurate testing, and are guaranteed for 24 months from the date of purchase. DELTA OHM will repair or replace free of charge the parts that, within the warranty period, shall be deemed non efficient according to its own judgement. Complete replacement is excluded and no damage claims are accepted. The DELTA OHM guarantee only covers instrument repair. The guarantee is void in case of incidental breakage during transport, negligence, misuse, connection to a different voltage than that required for the appliance by the operator. Finally, a product repaired or tampered by unauthorized third parties is excluded from the guarantee. The instrument shall be returned FREE OF SHIPMENT CHARGES to your dealer. The jurisdiction of Padua applies in any dispute.



The electrical and electronic equipment marked with this symbol cannot be disposed of in public landfills. According to the Directive 2011/65/EU, the european users of electrical and electronic equipment can return it to the dealer or manufacturer upon purchase of a new one. The illegal disposal of electrical and electronic equipment is punished with an administrative fine.

This guarantee must be sent together with the instrument to our service centre.

IMPORTANT: Guarantee is valid only if coupon has been correctly filled in all details.

Instrument Code: **HD51.3D4R** **HD51.3D4R-AL**

Serial Number _____

RENEWALS

Date _____

Date _____

Inspector _____

Inspector _____

Date _____

Date _____

Inspector _____

Inspector _____

Date _____

Date _____

Inspector _____

Inspector _____



The quality level of our instruments is the result of the constant development of the product. This may produce some differences between the information written in this manual and the instrument you have purchased. We cannot completely exclude the possibility of errors in the manual, for which we apologize.

The data, images and descriptions included in this manual cannot be legally asserted. We reserve the right to make changes and corrections with no prior notice.

V1.2
20/09/2018